

OPERATING INSTRUCTIONS UPS

AEG

PROTECT B.

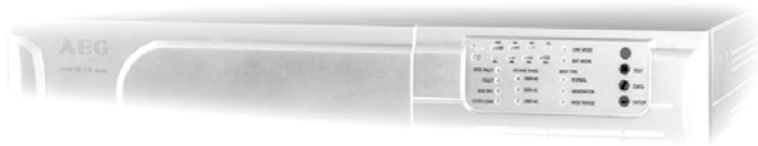

PROTECT B. 750
PROTECT B. 1000
PROTECT B. 1500
PROTECT B. 2000
PROTECT B. 3000

Thank you for purchasing a PROTECT B. UPS from AEG Power Solutions.

The following security advices are an important component of the manual and will prevent any operation errors and protect you against possible dangers. Read the manual thoroughly before you first use the appliance.

1 **Notes on these Operating Instructions**

Duty to Provide Information

These operating instructions will help you to install and operate the Uninterruptible Power Supply (UPS), PROTECT B. 750, PROTECT B. 1000, PROTECT B. 1500, PROTECT B. 2000 or PROTECT B. 3000 as well as the associated external battery units PROTECT B. 1500 BP, PROTECT B. 2000 BP or PROTECT B. 3000 BP – all referred to as PROTECT B. in this document – safely and properly, and for its intended purpose. These operating instructions contain important information necessary to avoid dangers during operation.

Please read these instructions carefully prior to commissioning!

These operating instructions are a composite part of PROTECT B.

The operator of this unit is obliged to communicate these operating instructions to all personnel transporting or starting up PROTECT B. or performing maintenance or any other work on the unit.

Validity

These operating instructions comply with the current technical specifications of PROTECT B. at the time of publication. The contents do not constitute a subject matter of the contract, but serve for information purposes only.

Warranty and Liability

Our goods and services are subject to the general conditions of supply for products of the electrical industry, and our general sales conditions. We reserve the right to alter any specifications given in these operating instructions, especially with regard to technical data and operation.

Claims in connection with supplied goods must be submitted within eight days of receipt, along with the packing slip. Subsequent claims cannot be considered.

The warranty does not apply for damage caused by non-compliance with these instructions (such damage also includes damaging the warranty seal). AEG will accept no liability for consequential damage. AEG will rescind all obligations such as warranty agreements, service contracts, etc. entered into by AEG and its representatives without prior notification in the event of maintenance and repair work being carried out with anything other than original AEG spare parts or spare parts purchased by AEG.

Handling

PROTECT B. is designed and constructed so that all necessary steps for start-up and operation can be performed without any internal manipulation of the unit. Maintenance and repair work may only be performed by trained and qualified personnel.

Illustrations are provided to clarify and facilitate certain steps.

If danger to personnel and the unit cannot be ruled out in the case of certain work, it is highlighted accordingly by pictograms explained in Chapter 3.

Hotline

If you still have questions after having read these operating instructions, please contact your dealer or our "Hotline":

Tel.: +49 (0)180 5 234 787

Fax: +49 (0)180 5 234 789

Internet: www.AEGpartnernet.com

Copyright

No part of these operating instructions may be transmitted, reproduced and/or copied by any electronic or mechanical means without the express prior written permission of AEG.

© Copyright AEG 2009. All rights reserved.

Table of Contents

1	Notes on these Operating Instructions	3
2	System Description	7
2.1	Overview	7
2.2	Functionality	8
3	Safety	10
3.1	General Safety Instructions	10
3.2	Safety Instructions for PROTECT B.....	10
3.3	Certification	14
3.4	Technical Data	15
4	Set-Up and Operation	20
4.1	Unpacking and Inspection.....	20
4.2	Point of installation	21
4.3	Connections, Operation / Display Elements.....	22
4.3.1	Front view:.....	22
4.3.2	Operating panel	23
4.3.3	Rear view (connections):	24
5	Commissioning.....	26
5.1	Deployment	26
5.1.1	Tower (Stand alone deployment).....	26
5.1.2	19" Rack Mount Setup	28
5.2	Additional battery installation setup	32
5.3	Emergency Power Off (EPO) set up	33
5.4	Electric start-up	34
5.4.1	Connection.....	34
5.4.2	Configuration.....	35
5.5	Operation.....	36
5.5.1	Normal Operation.....	36
5.5.2	Battery Operation / Autonomous Operation	36
5.5.3	Unit Overload	37
5.5.4	System Diagnosis / Battery Test.....	38

5.6	Interfaces and communication	39
5.6.1	Data line protection RJ11 and RJ45 (modem / telephone / fax / network).....	39
5.6.2	Computer interfaces RS232 and USB	40
5.6.3	Communication slot (PROTECT B.1500 / B.2000 / B.3000):.....	40
5.6.4	Shutdown and UPS management software	40
6	Signalling and failure solution	42
6.1	LED display	42
6.2	Audible Alarm Trouble Shooting:	44
6.3	General Fault Diagnosis and Fault Rectification	44
7	Maintenance	46
7.1	Battery replacement	47
8	Storage, Dismantling and Disposal	52
9	Glossary	53
9.1	Technical terms.....	53

2 System Description

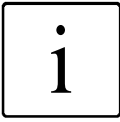

PROTECT B. is an Uninterruptible Power Supply (UPS) for essential loads such as PCs, workstations, servers, network components, telecommunication equipment and similar devices.

The PROTECT B. series is a compact, interactive, sinusoidally operating USP, available with an output power rate of 750, 1000, 1500, 2000 and 3000 VA.

The design of the USP allows horizontal / lying operation (Rack/19" with 2U) and vertical / standing operation (Tower).

2.1 Overview

The front of the UPS provides several LEDs and four push buttons for easy configuration, control and management. The panel also informs about the state of the power in the alternating current (AC) branch, indications on net failures and the charging state of the Output of the UPS. You will find two LED bars for output load and battery capacity, two state indicators (net available, battery active) and four alarm indicators (power failure, failure, battery discharged, overload). With the push button the acoustic alarm can be deactivated and the self test of the UPS will be started.

Power connectors, communication interfaces and connections for telephone and network are located on the rear of the PROTECT B. Important UPS parameters and data are constantly monitored and are transmitted via USB or serial RS232 to the "CompuWatch" Software on the management computer. The optional SNMP adapter allows remote monitoring via SNMP connector and multi server shutdown (starting with B.1500).

The main features of the PROTECT B. are:

- ◆ VI (Line Interactive) protection technology with sinusoidal output voltage
- ◆ AVR control system (automatic voltage regulation with mains operation)

- ◆ Micro processor control for high availability, suited for generator mode
- ◆ Easy extension of battery capacity using external batteries (starting with B.1500)
- ◆ Advanced battery management with integrated protection against extreme discharge and overcharge
- ◆ Overload and short circuit proof
- ◆ Maintenance free, sealed lead batteries, hot swappable (starting with B.1500)
- ◆ User friendly display for optimal readability / configuration
- ◆ Intelligent monitoring system with USB and RS232 interface
- ◆ Surge protection (RJ11 / RJ45) for phone, fax, modem and network (10/100MBit/s)
- ◆ Expansion slot for extension cards, i.e. SNMP (starting with B.1500)
- ◆ “CompuWatch” software for shutdown, state report and measurement for all popular operating systems (among others Windows, Mac, Linux)
- ◆ Compact design / variable deployment due to combination design as tower / rack (19” kit available optionally for all models)

2.2 Functionality

The UPS is connected to a shockproof socket between the public utility's mains and the loads to be protected.

Under normal operating conditions, i.e. if PROTECT B. is supplied with mains voltage, the battery charger will ensure that the battery is always completely charged.

During this operating status, the loads connected to PROTECT B. are supplied with voltage via mains filters which provide effective protection against mains voltage peaks and high-frequency faults.

In case of sustained mains undervoltage or overvoltage within defined ranges, the automatic voltage regulator (AVR) further

stabilizes the load voltage. As a result, voltage fluctuations in the public utility's mains are reduced to a level which is acceptable for the loads. This is performed without recourse to the internal energy storage, something which in turn has a positive effect on battery availability.

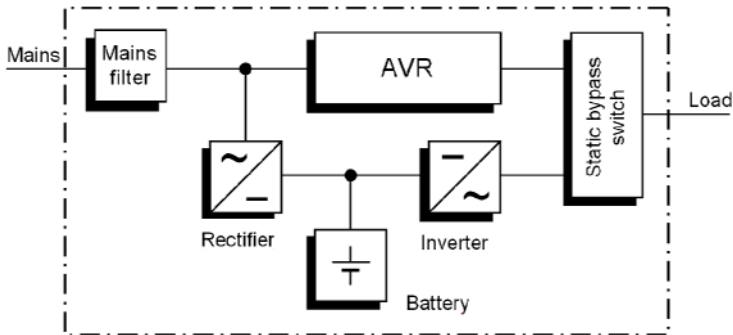

UPS block diagram PROTECT B.

The static bypass switch is activated in the event of a mains failure. The inverter then takes over the voltage supply of the connected loads, in order to prevent the risk of data loss or damage to the loads. PROTECT B. supplies voltage until the battery is discharged, allowing you to shut down your IT system properly and switch it off. The standby time mainly depends on the connected loads. If the mains power supply is back to normal values, the UPS will switch back the loads to mains supply. The battery charger will then recharge the battery.

For safety reasons (as required by German standards, VDE), the mains input in the unit will be disconnected by a two-pole switch in the event of a mains failure. Energy backfeed to the mains and voltage supply to the pins of the mains connector are thus reliably avoided.

Furthermore, additional protective measures ensure effective protection for the data/network interface.

3 Safety

3.1 General Safety Instructions

Read these operating instructions carefully prior to commissioning of the PROTECT B. UPS and observe the safety instructions!

Only use the unit if it is in a technically perfect condition and always in accordance with its intended purpose, while being aware of safety and danger aspects, and in accordance with the operating instructions! Immediately eliminate any faults which could be detrimental to safety.

The following pictograms are used in these operating instructions to identify dangers and important information:



Danger!

Identifies risk of fatal injury to the operator.



Attention!

Identifies risk of injury and risk of damage to the unit and parts of the unit.

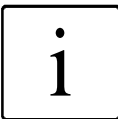

Information!

Useful and important information for operating the UPS.

3.2 Safety Instructions for PROTECT B.

This chapter contains important instructions for the PROTECT B. UPS. These must be followed during assembly, operation and maintenance of the uninterruptible power supply and the batteries.



The UPS carries high voltage. Danger! The unit may only be opened by trained and qualified personnel. Repairs may only be carried out by qualified customer service staff!



The output may be live, even if the UPS is not connected to the mains supply, as the UPS has its own internal power supply (battery)!



For health and safety reasons, the unit must be earthed correctly!

PROTECT B. may only be operated with or connected to a 230 Vac mains with protective grounding using a mains connection cable with PE conductor (included in the delivery) that has been tested in accordance with German standards (VDE).

Danger! Risk of burning!



The battery has powerful short-circuit currents. Incorrect connection or isolation faults can lead to melting of the plug connections, sparking potential and severe burns!



The unit has a warning signal that sounds when the battery voltage of PROTECT B. is exhausted or when the UPS is not working in its normal mode.



Observe the following safety instructions to ensure permanent operational safety of and safe work with the UPS:

- ◆ Do not dismantle the UPS! (The UPS does not contain any parts which require regular maintenance. Bear in mind that the warranty will be invalidated if the unit is opened!)
- ◆ Do not install the unit in direct sunshine or in close proximity of heaters!
- ◆ The unit is designed to be installed inside in heated rooms. Never install the UPS in the vicinity of water or in an excessively damp environment!
- ◆ Condensation may occur if the UPS is brought from a cold environment into the room where it is to be installed. The UPS must be absolutely dry prior to start-up. As a result, leave it to acclimatize for at least two hours.

- ◆ Never connect the mains input to the UPS output.
- ◆ Ensure that no fluids or foreign bodies can penetrate the UPS!
- ◆ Do not block the air vents of the unit! Keep children away from the unit and ensure that objects are never inserted through the air vents!
- ◆ Do not connect household appliances such as hairdryers to the UPS!
- ◆ The mains connection should be near the unit and easily accessible to facilitate disconnecting the AC input or pulling out the plug!
- ◆ During operation, do not disconnect the mains connection cable from the UPS or from the socket outlet in the building (shockproof socket), otherwise the protective grounding of the UPS and all the loads connected to it will be cancelled.



Danger! Electric shocks!

Even after the mains voltage has been disconnected, the components within the UPS remain connected to the battery and can thus cause electric shocks. It is therefore imperative to disconnect the battery circuit before carrying out any maintenance or repair work!



If it is necessary to replace the battery or carry out maintenance work, this must be done by or under the supervision of a specialist familiar with batteries and the necessary safety precautions!

Only authorised persons are allowed in the vicinity of the batteries!

When replacing the battery/batteries, the following must be observed: Only ever use identical maintenance-free sealed lead batteries with the same data as the original battery/batteries.



Danger! Explosive!

Never throw batteries into open fire. Never open or damage batteries. (Electrolyte may leak out and damage skin and eyes. It may be toxic!)



Batteries can cause electric shocks and high short-circuit currents.

Therefore, take the following safety precautions when working with batteries:

- ◆ Take off watches, rings and other metallic objects!
- ◆ Only use tools with insulated handles!



For personal safety reasons, never switch on the main switch when the mains connector of PROTECT B. is disconnected!

3.3 Certification

AEG

Power Solutions

Declaration of Conformity

Document - No. CE 0061

We

AEG Power Solutions GmbH
Emil – Siepmann – Straße 32, D – 59581 Warstein

declare under our sole responsibility that the product

Uninterruptible Power Supply (UPS)
Protect B.
type power 750VA / 1000VA / 1500VA / 2000VA / 3000VA

to which this declaration relates is in conformity with the following standards or other normative documents

EN 62040-1-1:2003
EN 50091-2:1995 clause 2.4/2.5 class A
EN 61000-3-2:1995
EN 61000-3-3:1995

Following the provisions of directives

89 / 336 / EEC	EMC Directive
73 / 23 / EEC	Low Voltage Directive
93 / 68 / EEC	Marking Directive

Year of labelling the CE – Mark: 2005

Germany, 59581 Warstein, 03.12.2008

AEG Power Solutions GmbH
Quality Management

.....
(Filmar)

AEG Power Solutions GmbH
Product Management
Compact UPS

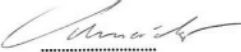
.....
(Schneider)

3.4 Technical Data

Model power

PROTECT B. 750	750 VA / 500 W
PROTECT B. 1000	1000 VA / 700 W
PROTECT B. 1500	1500 VA / 1050 W
PROTECT B. 2000	2000 VA / 1340 W
PROTECT B. 3000	3000 VA / 2100 W

UPS Input

Rated output voltage	220 / 230 / 240 Vac
Input voltage range	154 / 161 / 168 Vac \pm 4% (wide) 176 / 184 / 192 Vac \pm 4% (standard) until 264 / 276 / 288 Vac \pm 4%
Frequency (autom. detection)	50 / 60 Hz \pm 5 Hz > 40 Hz (generator mode)
Curr. consumption (full-load)	
PROTECT B. 750	5 A
PROTECT B. 1000	8 A
PROTECT B. 1500	10 A
PROTECT B. 2000	10 A
PROTECT B. 3000	16 A
Connection	IEC power connector (IEC 320)

USP output

Rated output voltage / AVR-technology	220 / 230 / 240 Vac
Rated output voltage in battery mode	\pm 5 %
Frequency in battery mode	50 Hz / 60 Hz \pm 0.1 Hz

Output current power (at 230 Vac)	
PROTECT B. 750	3.2 A
PROTECT B. 1000	4.3 A
PROTECT B. 1500	6.5 A
PROTECT B. 2000	8.7 A
PROTECT B. 3000	13 A
Transfer time at mains outage	2-4 ms (typical), 6 ms max. 13 ms max. in generator operation
Voltage waveform	sinusoidal
Outlets	Non-heating appliance connectors acc. to IEC 320
Overload response at mains operation	110% for 3 min. / 150% for 200 ms
Overload response at battery operation	110% for 30 s / 120% for 100ms
Overheat and short circuit protection	Yes

Battery

Autonomy time at rated load	5 min. Extendable from B.1500
-----------------------------	----------------------------------

Rated time with external battery packs

Number of connected battery packs	Autonomy time at rated load				
	1500 VA Tower	1500 VA Rack	2000 VA Tower	2000 VA Rack	3000 VA Tower/Rack
1	15 min.	---	15 min.	---	24 min.
2	30 min.	30 min.	27 min.	27 min.	45 min.
3	50 min.	---	40 min.	---	55 min.
4	65 min.	65 min.	50 min.	50 min.	75 min.

Deep discharge protection / Overload protection	yes
--	-----

Recharge time (to 90 % of rated capacity)	3 h (UPS in standard configuration) 7 h (UPS with 1 add. battery pack) 12 h (UPS with 2 add. battery packs) 18 h (UPS with 3 add. battery packs) 24 h (UPS with 4 add. battery packs)
Type	Sealed, maintenance free, hot swappable (from B.1500)
PROTECT B. 750	12 V / 7 Ah x 2
PROTECT B. 1000	12 V / 9 Ah x 2
PROTECT B. 1500 / B. 1500BP	12 V / 7 Ah x 4
PROTECT B. 2000 / B. 2000BP	12 V / 9 Ah x 4
PROTECT B. 3000	12 V / 5 Ah x 8
PROTECT B. 3000 BP	12 V / 5 Ah x 8 x 2

Communication

Interfaces	USB and RS232 Additionally from PROTECT B.1500: Communication slot for i.e. SNMP as well as input contact for emergency shutdown
Shutdown-Software on CD	For all typical operating systems, e.g. Windows, Linux, Mac, Unix, FreeBSD, Novell, Sun

Physical data

Noise (1 m distance)	< 45 dB(A)
Operation temperature range	0°C - 40°C
Humidity	0 - 90% (without condens.)
Installation height	up to 1000 m at rated power

Number of outlets	
PROTECT B. 750	4 x IEC 320
PROTECT B. 1000	6 x IEC 320
PROTECT B. 1500	6 x IEC 320 (sep. module)
PROTECT B. 2000	6 x IEC 320 (sep. module)
PROTECT B. 3000	8 x IEC 320-10 A 1 x IEC 320-16 A
Equipment colour	Black line
Size W x H x D (mm) (Size in horizontal / lying view)	Standard model
PROTECT B. 750	235 x 88 x 383
PROTECT B. 1000	235 x 88 x 383
PROTECT B. 1500 + B.1500BP	(2 x 217) x 88 x 414
PROTECT B. 2000 + B.2000BP	(2 x 217) x 88 x 414
PROTECT B. 3000	438 x 88 x 582
PROTECT B. 1500BP	217 x 88 x 414
PROTECT B. 2000BP	217 x 88 x 414
PROTECT B. 3000BP	438 x 88 x 582
Weight (kg)	
PROTECT B. 750	8.6 kg
PROTECT B. 1000	9.6 kg
PROTECT B. 1500 + B.1500BP	18.5 kg
PROTECT B. 2000 + B.2000BP	18.5 kg
PROTECT B. 3000	31.5 kg
PROTECT B. 1500BP	12.0 kg
PROTECT B. 2000BP	12.0 kg
PROTECT B. 3000BP	40.5 kg
Cooling	boosted self cooling
Store temperature range	-15°C - +50°C (UPS electronic)
Battery / UPS with integr. battery	0°C - +35°C
Certification	CE

Guidelines

The PROTECT B. complies with the product norm EN 50091.

The CE symbol on the unit certifies the compliance to the EG guidelines for 73/23 EEC low voltage and for 89/336 EEC electromagnetic compatibility (EMC), when following the installation instructions in the manual.

For the 73/23 EEC low voltage guidelines

Reference number EN 62040-1-1 : 2003

For the 89/336 EMC guidelines

Reference number EN 50091-2 : 1995

EN 61000-3-2 : 1995

EN 61000-3-3 : 1995

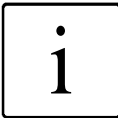

Warning:

This is a class A – UPS product. In a domestic environment, this product may cause radio interference, in which case, the user may be required to take additional measures.

4 Set-Up and Operation

4.1 Unpacking and Inspection

The unit has been fully tested and inspected. Although the unit has been packed and shipped with the usual degree of care, damage during transport cannot be ruled out completely.

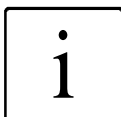

Claims for damage during transport must always be made with the transport company!

Check the shipping container for damage on arrival. If necessary, ask the transport company to check the goods and make a record of the damage in the presence of the member of staff from the transport company and register the damage with the AEG representative or dealer within eight days of delivery.

Check the delivery is complete:

- ◆ PROTECT B. with 700, 1000, 1500, 2000 or 3000 VA
- ◆ Two plastic feet plus two fixing bras (for B.3000)
- ◆ Mains connection cable with shockproof plug
- ◆ Two load connection cables
- ◆ USB / RS232 communication cable
- ◆ CD with "CompuWatch" shutdown software
- ◆ Operating instructions

Check for complete delivery of ordered options like additional battery modules, 19" mounting kits or communication options like a SNMP card etc.

Please contact our hotline (see page 4) in case of any discrepancy.

The original packaging provides effective protection against mechanical shocks and should be retained so the unit can be transported safely later on.



Please keep the plastic packaging bags away from babies and children in order to safeguard against suffocation accidents.



Handle the components with care. Please take into account their weights. It may be necessary to engage the help of a second person, particularly in the case of the PROTECT B. 3000 model.

4.2 Point of installation

PROTECT B. is designed to be installed in a protected environment. When installing the unit, pay attention to such factors as sufficient ventilation and suitable ambient conditions.



PROTECT B. is air-cooled. Do not obstruct the air vents!

The UPS should preferably be operated at room temperature (between 15°C and 25°C).

Install the UPS in a room that is dry, relatively dust-free and free of chemical vapours.

Make sure that no magnetic storage media are stored and/or operated close to PROTECT B.



Check the nameplate to make sure the voltage and frequency data correspond to the values applicable to your loads.

4.3 Connections, Operation / Display Elements

4.3.1 Front view:

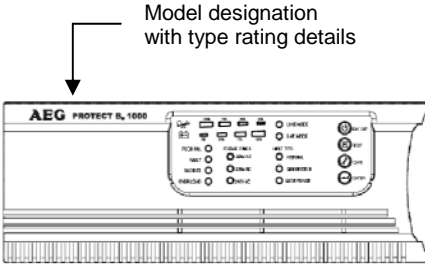

PROTECT B. 750 and B. 1000

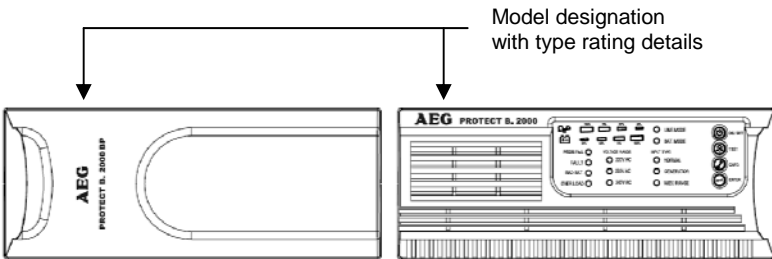

PROTECT B. 1500 and B. 2000 (Battery module and UPS)

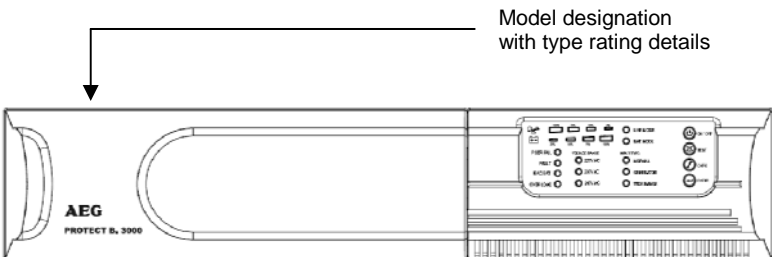

PROTECT B. 3000

4.3.2 Operating panel

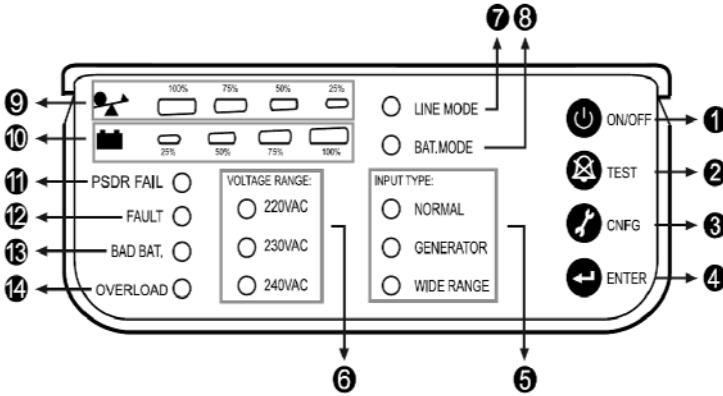

Explanations (see also chapter 6)

1. Main switch of the UPS (mains switch)
2. Pushbutton for system test (manually triggering) or switching off the buzzer
3. Pushbutton to view the configuration
4. Enter button
5. LED for operating mode (details on page 42)
6. LED for current output rate voltage
7. LED for line mode
8. LED for battery mode
9. Bar graph LEDs for load level
10. Bar graph LEDs for battery capacity (remaining autonomy time)
11. LED for rectifier failure
12. LED error display (e.g. UPS overtemperature, short circuit)
13. LED for battery problem (e.g. discharged)
14. LED for fails/overload is timed out /or short output

4.3.3 Rear view (connections):

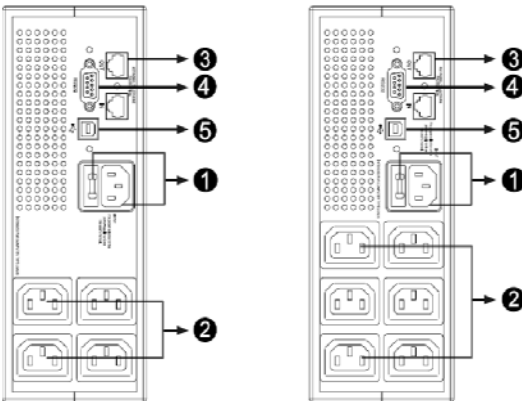

PROTECT B. 750 und 1000

Comments:

1. Mains connection (UPS input) with electric fuse and integrated spare fuse
2. Load connections (UPS outputs)
3. Surge protection (RJ11/RJ45) for data interface for phone, fax, modem or network (10/100MBit/s)
4. Communication interface RS232 (9pin SUB-D socket)
5. USB communication interface

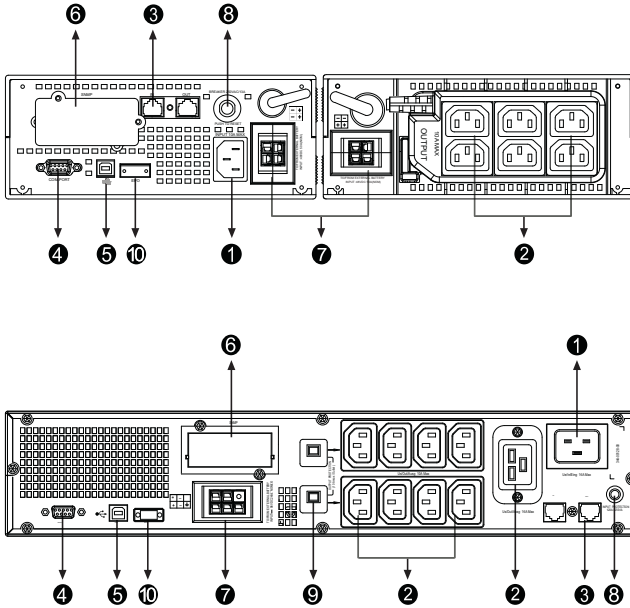

Comments:

1. Mains connection (UPS input)
2. Load connections (UPS outputs)
PROTECT B. 3000 with additional load connection (IEC 320-16A)
3. Surge protection (RJ11/RJ45) for data interface for phone, fax, modem or network (10/100MBit/s)
4. Communication interface RS232 (9pin SUB-D socket)
5. USB communication interface
6. Communication slot for optional expansion cards
7. Connection for external battery module (battery extension)
8. Mains input circuit breaker
9. Circuit breaker for load connections (only for PROTECT B. 3000)
10. Input contact for emergency shutdown (EPO)

5 Commissioning

5.1 Deployment

The UPS was constructed for both horizontal / flat (rack/19") operation and vertical / standing (tower) operation.



Operation the unit for longer time above an ambient temperature of 25° C reduces the lifetime of the batteries.



Position the UPS unit at least 20 cm away of any other electronic equipment to prevent interference.

After deployment and assembly of the UPS follow the steps for activation as explained in chapter 5.4

5.1.1 Tower (Stand alone deployment)

All models are qualified for stand alone use. PROTECT B. 750 and 1000 consist each of only one component and can be set up either standing or lying position

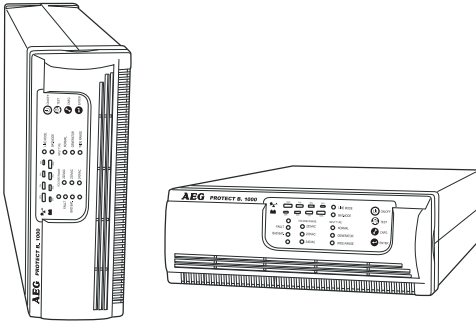

PROTECT B. 750 / 1000 standing and lying

PROTECT B. 1500 and B.2000 are operated always in combination with at least one additional battery module. Because of the air intake in the front and the rear there is a variety of deployment positions.

When operating the system with more than one battery module, the UPS can be positioned between the modules. The following graphic displays the possibilities:

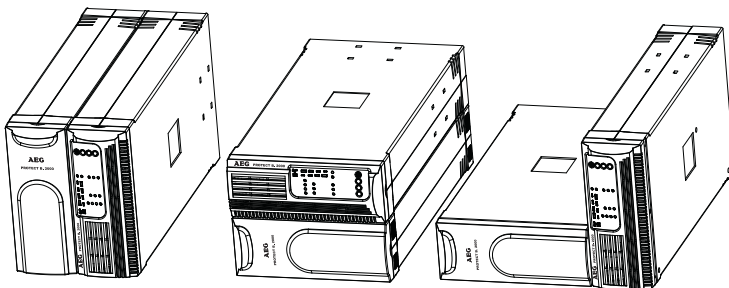

PROTECT B. 1500 / 2000 standing and lying (standard version)

PROTECT B. 3000 can be operated in the standing and lying position as well. Putting up the UPS upright requires the use of the two provided supports. The supports have to be positioned in the front third and rear third of the unit.

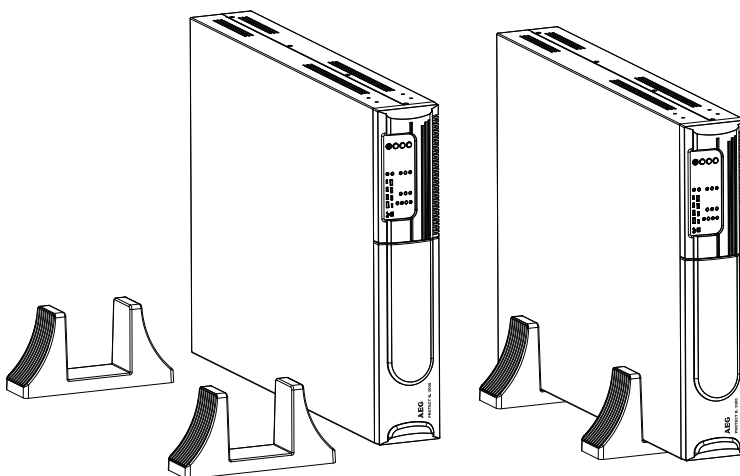

PROTECT B. 3000 standing

Please consider for the location of setup also the guidelines on page 21 of the manual.

5.1.2 19" Rack Mount Setup

ROTECT B. 750, 1000, 1500, 2000 and 3000 can be installed in 19" racks. The UPS and external battery enclosure need 2U of valuable rack space. Mount the UPS preferable in the lower third of the rack with respect to the mass centre and sufficient ventilation.

Use the optional 19" mounting kit for the installation in the rack.

PROTECT B. 750 und B.1000

1. Fix the mounting ears on the side of the UPS according to the following figure.

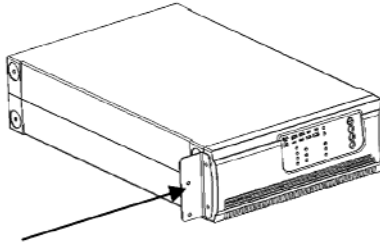

2. Mount these subsequently to the slide assemblies.

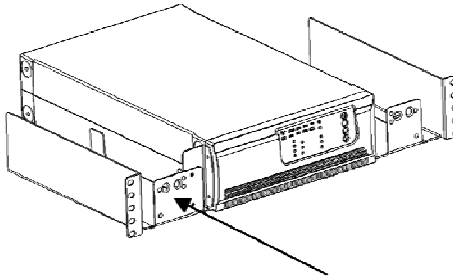

3. Insert UPS into the slide assemblies and lock it in the rack enclosure.

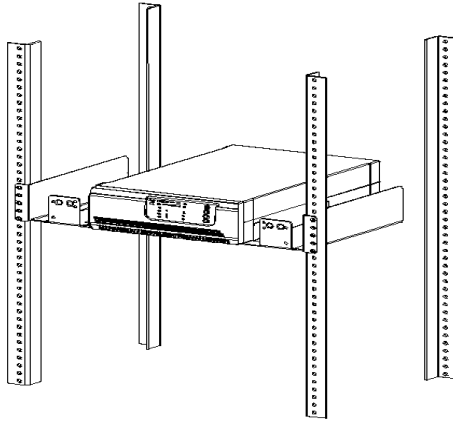

4. Add up the front panels for both sides. The mechanical installation of the UPS is completed now.

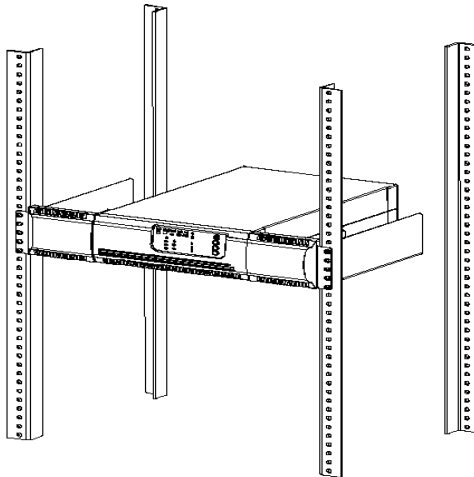

PROTECT B. 1500 und B. 2000

This model is designed such that the UPS and the battery module can be mounted beside each other into the rack.

1. Place the UPS on a flat and in a clean place that the front side of the UPS is facing to you.

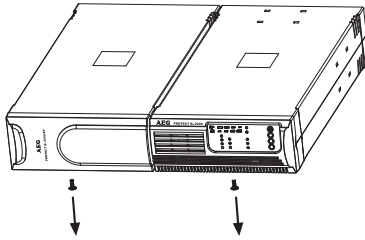

2. Loosen the screws in the middle of the cover and remove the covers from both units.

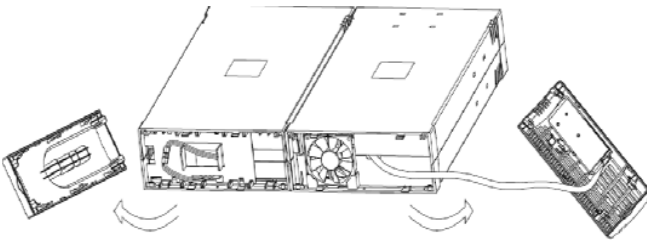

3. Fix the (wide) mounting bracket to the open front. Rack mounting holes stand out on each side of the units.

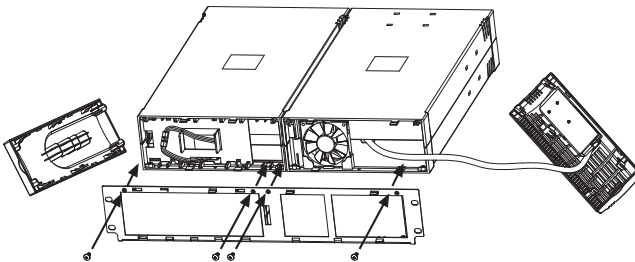

4. Secure the bracket with the supplied screws to the UPS and the battery module.
5. Reinstall the covers.

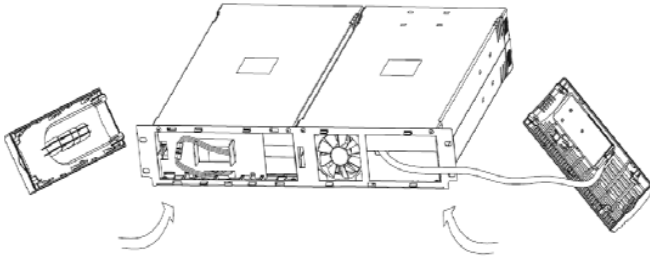

- Align the second (smaller) mounting bracket at the rear of both units and mount them with the enclosed screws.

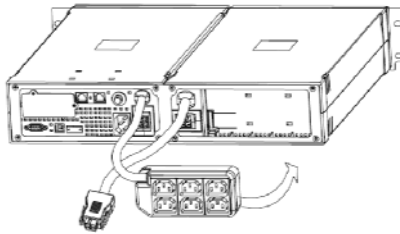

- Install Plug of the battery module with the socket at the rear panel of the USP. Fix the output module to the notch of the battery module.

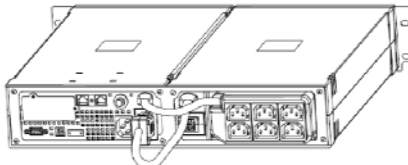

The setup of the rack-mount is completed.

PROTECT B. 1500 BP / B. 2000 BP

If you want to install optional external battery modules in a 19" rack use two of the units together and follow the steps 1 to 7 as described above.

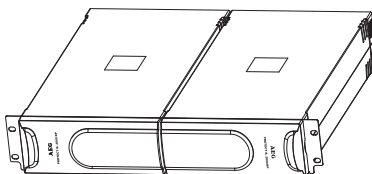

PROTECT B. 3000 / B. 3000 BP

For mounting the 3000 VA UPS in a 19" rack fix the mounting ears to the UPS and install the unit to the rails. Do the same for the optional battery module.

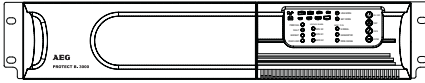

5.2 Additional battery installation setup

PROTECT B. 1500, 2000 und 3000 include external battery ports that allow connecting additional battery modules. This provides additional battery runtime.



Caution:

Connect the battery connectors quickly and check for a tight fit of the connections.

PROTECT B. 1500 und B. 2000

There is one external battery port on the UPS and on the battery pack.

1. Connect the battery cable to the external battery port of the rear of UPS.
2. Then connect the supplied battery cable from extended battery module to the external battery port on the rear of the UPS.

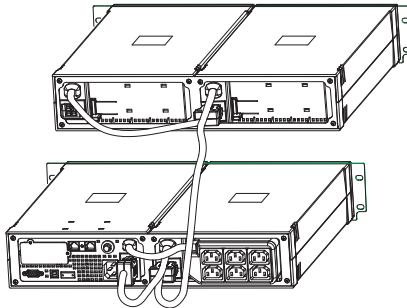

If continuing to add up extended battery packs, repeat above step.

PROTECT B. 3000

Connect the supplied battery module cable from extended battery module to the external battery port of the rear of UPS. If continuing to add up extended battery module, repeat above steps.

5.3 Emergency Power Off (EPO) set up

PROTECT B. 1500, 2000 and 3000 include EPO port that allows power to be shut down the protected equipment immediately and does not follow the shutdown procedure from any power management software.

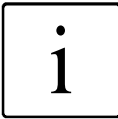

Note:

After pressing the EPO all outputs of the UPS are without power. For restarting the system you have to quit / reset the EPO and manually restart the UPS by pressing the on / off button.

Follow the procedure to install the EPO switch as below.

1. Check the UPS is turned off.
2. Remove the power supply from the EPO cradle on the rear of the UPS by loosening the two outer screws.
3. Connect isolated, normally-open, dry contacts (rated to handle 60Vdc maximum, 30Vac RMS maximum, and 20mA maximum) across the EPO device to Pin 1 and Pin 2.
4. Use non-shield wiring, size 0,3 mm² - 0.75 mm². Plug the connector into the socket and fix it by screwing the two outer screws tight.
5. Verify that the externally-connected EPO switch is not activated to enable power to the UPS output receptacles.
6. Plug in the UPS, then pressing power switch button to turn on the UPS.

7. Activate the external EPO switch to test the EPO function
8. De-activate the external EPO switch and restart the UPS.

5.4 Electric start-up

First compare the setting with the rated voltage valid in your country. The factory default setting is 230 V

Make any changes in accordance with the description in chapter 5.4.2 "Configuration".

5.4.1 Connection

Now connect the input of the UPS (pos. 1 fig. p. 24/25) to the mains connection cable provided and plug the mains connector into a suitable shockproof socket.

1. Avoid using extension cables and/or adapters. In particular in the case of high-capacity types, ensure that the fusing in your sub-distribution is adequately dimensioned: The PROTECT B. 3000 for example requires its own connection with a 16 A fuse. No other loads should be connected to this circuit!
2. Then connect the outputs of your UPS (pos. 2 fig. p. 24/25) to your loads. Use the load connection cables provided for this. Don't switch on the loads yet. Please contact your dealer if you require additional load connection cables.
3. Now switch on the UPS. To do this, press and hold the UPS main switch  for about 3 seconds until the display goes on.
4. The UPS acknowledges your command by starting a self test. During this automatically running procedure a periodically audible signal can be heard. The green "Mains" LED is permanently illuminated when the normal

operating stag has been reached (pos. 7 p. 3).
In case anything different occurs, please
follow the instructions in Chapters 6.2 / 6.3.

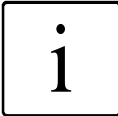





Please shut down the entire system if you cannot solve any problems which occur. Please contact our hotline (see page 4).

5. When the LINE MODE display is lit, switch on your loads one after the other. Note the maximum permitted UPS load when doing this (pos. 9 fig. p. 42).

In particular, bear in mind the considerable power consumption of loads such as laser printers, large CRT monitors and the like which can quickly lead to a UPS overload.

5.4.2 Configuration

To reconfigure the internal UPS setup options, follow the procedure as below:



1. Press the Configure  button more than three seconds. Then UPS will transfer from configure mode to “output voltage mode” showing the value by a flashing LED at 220 Vac, 230 Vac or 240 Vac.
2. Press the Configure  button more than one second, the UPS allows you to select the “output voltage mode” one by one.
3. After selecting the mode, press the Enter  button more than three seconds, the “output voltage mode” is configured.
4. UPS will automatically transfer from configure mode to “operating mode” displayed by a flashing LED beside NORMAL, GENERATOR or WIDE RANGE.
5. Press the Configure  button more than one second; the UPS will allow you to select the “operating mode” one by one.

6. After selecting the mode, press the confirmation button  more than three seconds to complete the configuration.

5.5 Operation

Once you have connected the UPS to a suitable mains connection, you can start operation using the UPS main switch.

On and Off switch

- ◆ To switch on the USP press the button  for about 3 sec. (until the display goes on).
- ◆ To switch off the UPS press the button  until the UPS signal stops.

Normally, the UPS operates continuously. The UPS now supplies the output with voltage, this being signaled by the green LED LINE MODE which lights up permanently (pos. 7 p. 42).

5.5.1 Normal Operation

During normal operation, i.e. when mains voltage is available, the built-in battery charger keeps the battery fully charged and the mains voltage monitoring system switches the inverter to standby mode.

The connected loads are powered using the monitored and filtered mains voltage, which is additionally stabilised by the integrated AVR control unit.

The UPS capacity utilisation can be read off the bar chart of the operating panel (pos. 9, fig. p. 42).

5.5.2 Battery Operation / Autonomous Operation

When there is a mains failure or if the input voltage moves outside the tolerance range, the inverter automatically switches over to autonomous mode and supplies the loads with voltage from the battery. This drains the capacity of the battery and it is discharged. This status is signalled by the yellow LED BAT.MODE flashing as well as an intermittent acoustic signal (s. p. 42)

If the UPS does not automatically return to normal operation after a few minutes, close all jobs as usual and switch off your loads (e.g. PC) before the battery is fully discharged. This lengthens the service life of the battery! Switch OFF the UPS by pressing the main switch .

During the discharge process as the battery capacity consistently drops, the LED BAT.MODE flashes, accompanied by an intermittent double acoustic signal (once every four seconds). When the battery undervoltage limit is reached (acoustic signal every second), the electronic of the UPS switches off the power supply for the loads.

Never store the unit in this condition! The discharged battery system should be recharged within a week.



If the LED BAT.MODE flashes every second, it is time shut down the system and all connected loads! Shut down the UPS as well using the main switch.

When the mains voltage comes back, the UPS must be switched on again using the main switch  (only applies if it was previously switched off manually), in order to recharge the battery and thus store sufficient battery capacity for any possible future mains failures.

The batteries will be charged automatically when connected to the mains, independently of the mode set. The charging time after longer discharge of the batteries depends especially of the number of connected external battery units.

The charging time up to 90% of the rate capacity for a standard UPS is about 3 hours.

5.5.3 Unit Overload

If the unit is overloaded (load > 110 %), an intermittent signal is heard. The power supply to the connected loads is maintained, however the connected total load must be reduced immediately.

Non-observance of the "Unit overload" condition may cause the total loss of all UPS functions!

Also avoid short-term unit overloads, which may, for example, occur when connecting a laser printer or laser fax machine. Do not connect any household appliances to the UPS.





Never connect any additional loads to the UPS if there is a mains failure, i.e. if the UPS is working in emergency power operation.

The UPS output is de-energised if there is an overload of 150 % for longer than 200 ms during normal operation. During emergency power operation, an instant shutdown additionally takes place if there is a unit overload of > 120 % (see Chapter 3.4). As a rule, if there has never been an overload during normal operation, there will not be one during battery operation either.

5.5.4 System Diagnosis / Battery Test

It is possible to press the "TEST" button  (pos. 2 p. 42) to perform a manual check on the major hardware components of the UPS. This test can only be initiated if the unit is operating normally, and it involves switching the loads over to UPS inverter supply for a few seconds. As well as checking the procedures and the functional capability of the static bypass switch, this check also involves drawing current from the battery for a short time. The inverter has to provide the entire load supply, which means the entire process chain is tested with this function. Normal operation is restored after the check.

Executing the Test:

- ◆ To execute the manual check press the button  for about five seconds until the UPS acoustic signal fades out.
- ◆ Additionally the button has the function to deactivate the acoustic alarm signal. Press the button  when the acoustic alarm is audible for about 1 second. The tone stops. Any new error that is reported by a signal activates the alarm signal again.



Note:

The acoustic signal can not be switched off in the following situations:

Battery weak, overload, fan failure, fan error, time cutout, overheat.

If the monitoring electronics detect an irregularity during the procedure described above, the load is immediately switched back onto the mains and is thus supplied with voltage. At the same time, an acoustic fault signal and the corresponding signals from LEDs in acc. with Chapter 6 "Signalling" are output.



Faults detected and signalled during diagnosis must be rectified; otherwise there is a risk of load voltage loss if a mains failure occurs!

5.6 Interfaces and communication

5.6.1 Data line protection RJ11 and RJ45 (modem / telephone / fax / network)

The incoming data lines are connected to the "IN" line at the rear of the UPS. The "OUT" line is connected via data line with your terminal.

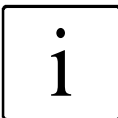

The data line protection supports networks with transfer rates between 10 and 100 MBit/s.

5.6.2 Computer interfaces RS232 and USB

The UPS offers various interfaces to manage the system and to comfortable readout state information and important parameters. The protocol is optimized for operation with the shutdown and UPS management software “CompuWatch” from AEG. To connect to the UPS use the provided RS232 or USB cable by attaching them to a free port of your pc.

RS232 interface: The interface is connected via a 9 pole Sub-D connector on the back of the unit (pos. 4 p. 24 / 25). PIN configuration: 2 = RxD; 3 = TxD; 5 = GND.

USB interface: The connection via USB is recognized automatically (pos 5 p. 24 / 25).

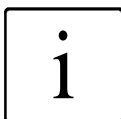

USB- and RS232 interfaces can not be used at the same time.

5.6.3 Communication slot (PROTECT B. 1500 / 2000 / 3000):

If the cover on the rear of the UPS is removed, additional optionally available communication components can be installed there.

SNMP board: Slot card for direct connection of the UPS to the Ethernet network with RJ 45 (TCP/IP)

Details can be found in the description enclosed with the particular optional component. Other boards are in preparation.

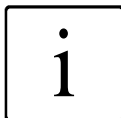

Using the communication slot deactivates the RS232 interface of chapter. 5.6.2.

5.6.4 Shutdown and UPS management software

Especially for monitoring the state of the UPS and the supply of power AEG developed the software “CompuWatch”.



In combination with the intelligent UPS the software ensures high availability of all IT components and full data integrity.

The shutdown software “CompuWatch” supports most popular operating systems like Windows 98/ME, WindowsNT/2000/XP, Linux, Novell Netware, IBM AIX, HP-UX, SUN Solaris, Mac OS X, ...

Details concerning installation on diverse operating systems can be found in the manual on the CD.

Download of updates via www.AEGpartnernet.com >> PRODUCTS >> Software >> CompuWatch

6 Signalling and failure solution

6.1 LED display

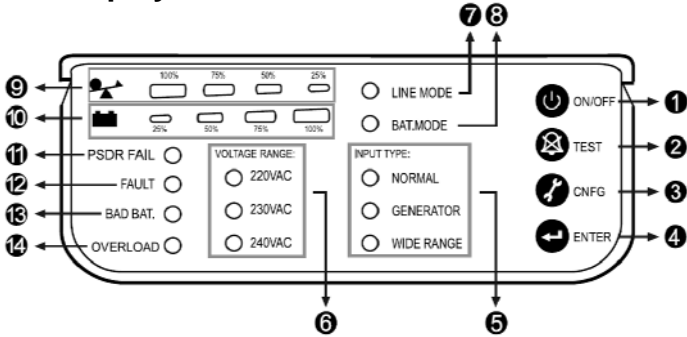



1. Main switch of the UPS (mains switch)
2. Push button for manually triggering the system test or switching off the buzzer
3. Push button to view the configuration
4. Acknowledgement button
5. **INPUT TYPE:** LED for preselected operation state and output voltage
 NORMAL: (Normal mode) The LED indicator will illuminate during normal mode, the UPS accepts AC input voltage range from +/-20%.
 GENERATOR: (Generator mode) No change to voltage window. However, the low frequency transfer point is changed to 40Hz and there is no limitation for high frequency transfer point.
 WIDE RANGE: (Extended UPS)
 AC input voltage ranges from -30% / +20%.
6. **VOLTAGE RANGE:** LED for current output rate voltage 220Vac / 230Vac (ex factory) / 240Vac.
7. **LINE MODE:** Green LED for power mode. The line LED indicator illuminates when the AC source is present.
8. **BAT. MODE:** Yellow LED for battery mode. The LED indicator will flash every four seconds when the UPS

is providing battery power to your equipment. On the other hand, the LED indicator gives you a warning which will flash every two seconds when the battery is low.

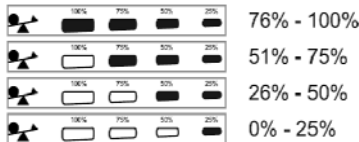
9.  **LED:** Bar chart LEDs showing UPS utilization. The LED indicator and the load level indicator will illuminate to show the load level; linearly subdivided in 25% steps.



10.  **LED:** Bar chart LEDs showing battery capacity (remaining standby time). The  LED indicator and battery level indicator will illuminate to show battery level. Each LED indicator displays a 25% capacity level.

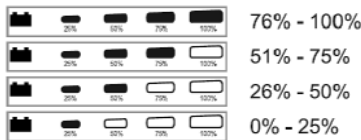

11. **PSDR FAIL:** LED error display for corrupt inverter.
12. **FAULT:** Central error LED display, e.g. when UPS is overloaded or encounters a short circuit on the output.
13. **BAD BAT.:** LED for battery problem (e.g. discharged). The LED indicator will flash every two seconds when the battery fails or if the battery is disconnected. Please check your battery connection; replace the battery or contact your local dealer for a battery replacement kit.
14. **OVERLOAD:** LED for violation of overload time limit. The LED indicator will light on when the UPS overload timeout. (Information concerning the time limit is available in chapter 3.4).

6.2 Audible Alarm Trouble Shooting:

Problem	Cause	Solution
Sounding every 4 seconds	The UPS is on battery	Check the input voltage, the input fuse resp. the circuit breaker
Sounding every second	The battery is running low	Save your work and turn off your equipment
	Output overload	Check load level indicator and remove some load
Continuously sounding	The UPS fails	Please contact your local dealer
	Battery may need to charge or service	Charge or replace the battery

6.3 General Fault Diagnosis and Fault Rectification

Problem	Cause	Solution
The UPS is not on when power switch is pressed	The power cord is not connected correctly	Check the power cord connection, especially the fit of the plug in the socket of the UPS
	The wall outlet may be faulty	Please contact your local qualified electrician
	The UPS output may short-circuit or overload	1. Disconnect all loads and restart UPS. Connect loads again one by one. 2. Ensure loads are not defective or shorted internally
	Internal fuse may be blown	Please contact your local dealer

UPS could not provide power to the load	Output fuse it released	Check the output fuse (B. 3000)
	UPS output recognizes overload or short circuit	Check the connected cable Ensure the load does not exceed the maximum rating of UPS
Battery has reduced backup time	Battery is not charged	Re-charge the battery at least 24 hours
	Battery may not able to hold a full charge due to age.	Replace Battery
Connected equipment lose power while connected to the UPS	The UPS may be over- loaded	Check the load status on the bar graph, reduce the load if necessary
	The UPS may be failed	Please contact your local dealer
The UPS fault LED lights on	The UPS fails	Save your work and turn off equipment. Please contact your local dealer

If you cannot solve the problem which has occurred, stop the entire procedure, switch off the UPS and disconnect the connector from the socket. Please contact our hotline in this case (see page 4).

Please have the serial number of the unit as well as the purchase date to hand in this case. The hotline will provide you with technical support and can inform you about further procedures once you have described the problem.

7 Maintenance

The PROTECT B. consists of advanced and resistant components. To guarantee a continuous and high availability it is recommended to check the unit (especially the batteries and the fans) in regular intervals (at least every 6 months).



CAUTION:

Follow safety and security regulations unconditionally!

Visual control

When going through the visual control check whether:

- ◆ mechanical defects or foreign matter is visible in the system
- ◆ conducting dirt or dust sediments are in the unit and
- ◆ dust sediments prevent optimal ventilation in and out the unit.



CAUTION:

Before going through the next step disconnect the PROTECT B. from the mains.

If the unit is very dusty it is recommended to clean the UPS with compressed air to enable optimal ventilation.

The time intervals for the visual control depend mainly on the local situation at the deployment site.

Battery control

The aging process can be detected by regular capacity probes. Make comparison measurements every 12 month e.g. by simulating a power failure and check how long the standby time lasts. The load should always be the same for each simulation. Dramatic changes compared to the last measurements require a change of batteries. Contact your local dealer or call our hotline (see page 4).

Fan control

The fan has to be checked on a regular basis for dust intrusion and strange untypical sounds. Clogged ventilation has to be cleaned. If the fan makes a strange noise or runs irregular contact the hotline (see page 4).

7.1 Battery replacement



CAUTION:

A battery can present a risk of electrical shock and can be very dangerous if handled improperly. The following precautions should be observed before replacing the batteries.

- ◆ Turn off the UPS and disconnect the utility power cord from the wall outlet.
- ◆ Remove rings, watches, and other metal objects.
- ◆ If the battery replacement kit is damaged in anyway or shows signs of leakage, contact your dealer immediately.
- ◆ Properly recycle or dispose of used battery. Do not dispose of batteries in a fire. The batteries may explode.

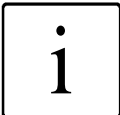

Note:

If you are not qualified service personnel to replace the battery, do not attempt to open the battery door. Please call local dealer or distributor immediately.

PROTECT B. 750 and B.1000

1. Unscrew the two screws on the side and remove the front panel carefully on both ends. Make sure that the panel does not tilt too much.

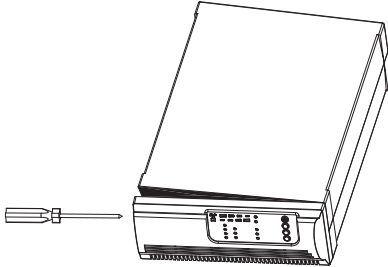

2. Disconnect the battery cable from the UPS and remove the battery retaining battery bracket to the right so that the battery can be pulled out to the front.

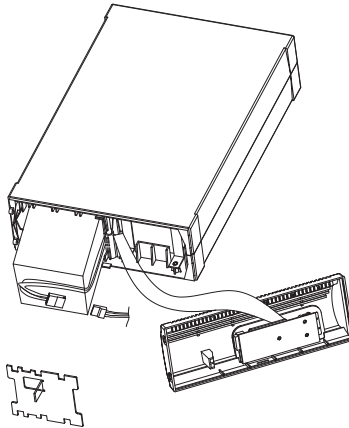

3. Withdraw the new batteries from the transport container and put into the right position. Fix both blocks together and connect the electric connections of the extracted battery system.
4. Slide the new battery carefully into shaft of the UPS until the end. Mount the bracket for fixing the battery pack and connect the system electrically. Push the contact together quickly and firmly. Take care of the right polarity (red - red / black - black)

5. Close and reinstall the front panel. Take care to push it in firmly and fix the front panel with the two screws from the beginning.

PROTECT B. 1500 und B. 2000

1. Unscrew the two screws from the battery case and remove front panel by pulling on both ends.

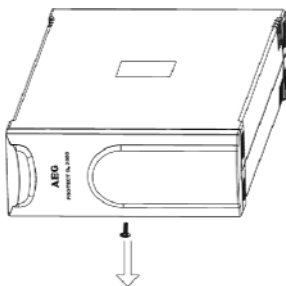

2. Disconnect the battery cable from the battery module and remove the bracket by sliding it to the side. (Remember the position of the bracket for the reassembly. The notches are good for orientation).

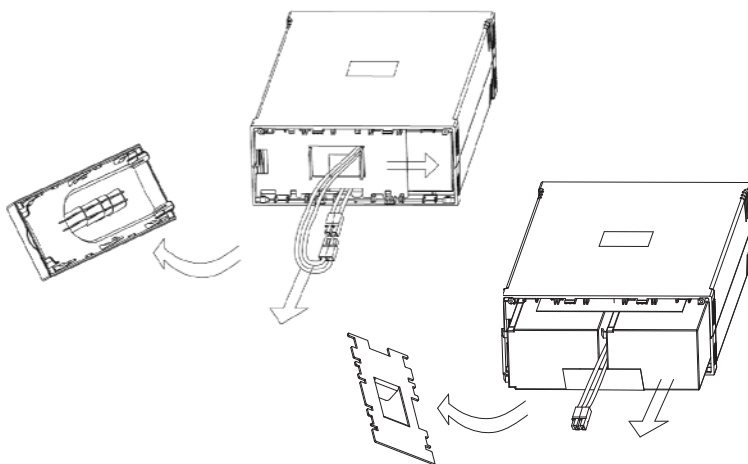

3. Withdraw the new batteries from the transport container and put into the right position. Fix both blocks together and connect the electric connections of the extracted battery system.
4. Slide the new battery carefully into shaft of the UPS until the end.
5. Mount the bracket for fixing the battery pack and connect the cable joint between the battery packs (red-red / black-black). Close and reinstall the front panel. Take care to push it in firmly and fix the front panel with the two screws from the beginning.

The battery exchange is completed.

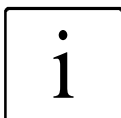

Alternatively a complete battery module can be provided ex factory as a spare part. Ask your local dealer or call the hotline (see page 4).

PROTECT B. 3000

1. Remove the left front panel carefully by pulling on both ends.

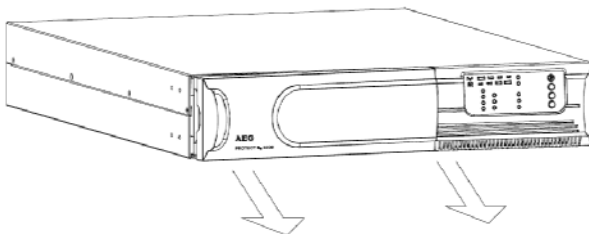

2. Disconnect the battery cable and remove the battery bracket.

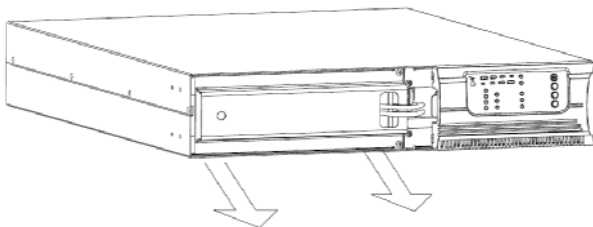

3. Pull first the right battery out and then the left one.

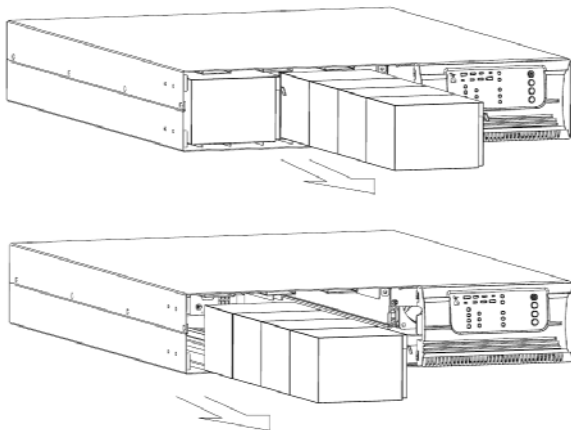

4. Withdraw the new batteries from the transport container and put into the right position. Fix both blocks together and connect the electric connections with the junction line of the extracted battery system.
5. Slide the new batteries into battery module carefully into the shaft.
6. Mount the bracket for fixing the battery pack and connect the system electrically (red - red / black - black).
7. Close and reinstall the previously removed front panel.

The battery exchange is completed.

8 Storage, Dismantling and Disposal

Storage



Long storage times without charging or discharging the battery at regular intervals may lead to permanent damage of the battery.

If the battery is stored at room temperature (20°C to 30°C) it will automatically discharge at a rate of 3-6 % per month due to internal reactions. Storing the battery at temperatures above room temperature should be avoided. A high storage temperature also means greater battery self-discharge.

Batteries that are stored at room temperature should be recharged every six months to maintain their full capacity and service life.

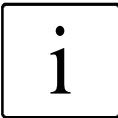

Connect PROTECT B. to the mains without load before putting it into storage, in order to make sure that the battery is fully charged.

The charging time should be at least as long as recommended in chapter 3.4 “Technical Data”.

Dismantling

The system is dismantled in reverse order of the installation instructions.

Disposal

In the interest of environmental protection and recycling, please dispose condemned components in accordance with the regulations and legal guidelines when permanently taking the system out of operation.

9 Glossary

9.1 Technical terms

AVR	<u>A</u> utomatic <u>V</u> oltage <u>R</u> egulation against mains voltage variations
DC/DC Booster	Circuit technology to boost the direct voltage on a higher voltage level
EPO	<u>E</u> mergency <u>P</u> ower <u>O</u> ff device for emergency shut down
PFC	<u>P</u> ower <u>F</u> actor <u>C</u> orrection Circuit technology to minimize circuit backfeed (important for non linear loads)
Appliance protection	Surge technology term The conventional mains surge protection consists of an mains earthwire (class B), an overvoltage protection (class C) and an appliance protection (class D) – see also e.g. under http://www.phoenixcontact.de (topic „TRABTECH“)
Class D	see appliance protection
LED	<u>L</u> ight <u>E</u> mitting <u>D</u> iode Electronic semiconductor component, commonly called light diode. Used for optical signaling.
SNMP	<u>S</u> imple <u>N</u> etwork <u>M</u> anagement <u>P</u> rotocol common protocol in networks to manage / control appliances
VFD	Output <u>V</u> oltage and <u>F</u> requency <u>D</u> ependent from mains supply The UPS output depends of mains voltage and frequency variations. Former notation: OFFLINE
VI	Output <u>V</u> oltage <u>I</u> ndependent from mains supply The UPS output is independent of mains voltage and frequency variations. The mains voltage however is rectified by electronic / passive voltage regulators. Former notation: LINE-INTERACTIVE
VFI	Output <u>V</u> oltage and <u>F</u> requency <u>I</u> ndependent from mains supply The UPS output is independent of mains voltage and frequency variations. Former notation: ONLINE

Guarantee certificate

Type:

Serial-no.:

Date of purchase:

Trading stamp / Signature

Specifications are subject to change without notice.

AEG

Power Solutions

AEG Power Solutions GmbH

Emil-Siepmann-Straße 32

59581 Warstein-Belecke

Germany

Operating Instructions UPS

BAL 8000015758_01 EN